

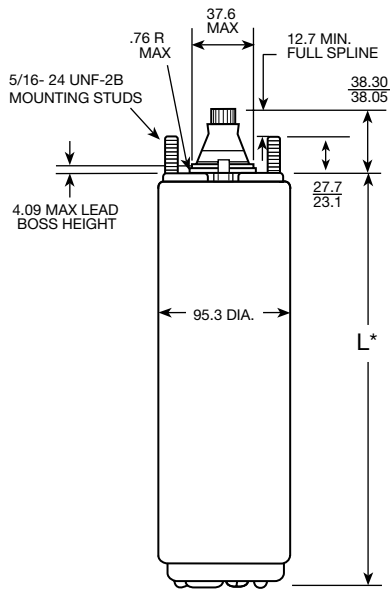

Installation - All Motors

4" Super Stainless - Dimensions (Standard Water Well)



4" High Thrust - Dimensions (Standard Water Well)

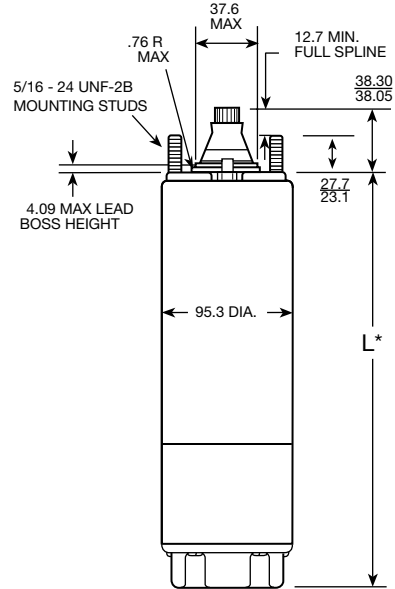

6" - Dimensions (Standard Water Well)

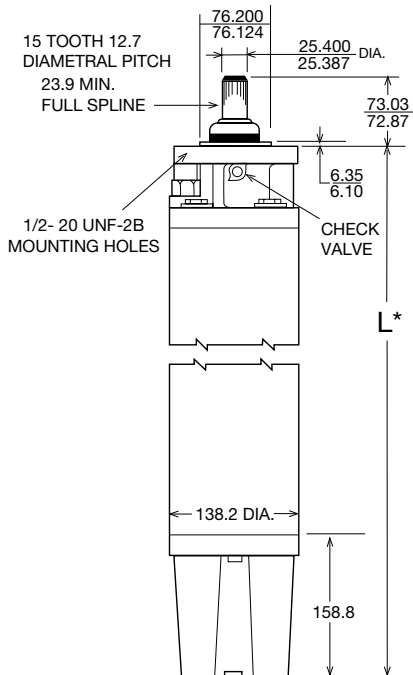

8" - Dimensions (Standard Water Well)

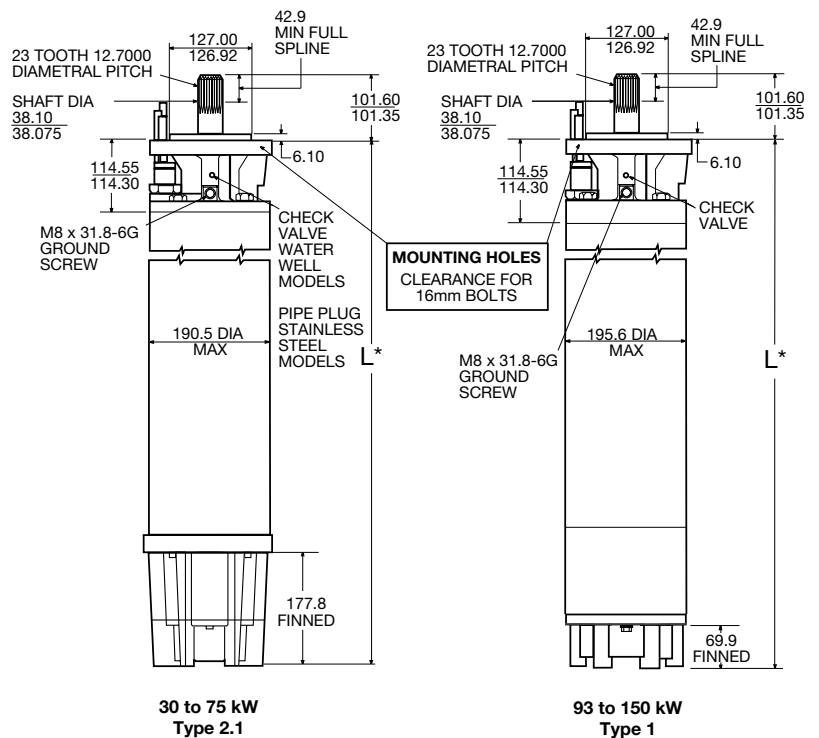

Dimensions in mm unless otherwise noted

* Motor lengths and shipping weights are available on Franklin Electric's web page (www.franklin-electric.com.au) or by calling Franklin on 1300 FRANKLIN.